

PRINCE

Prince Wafer Check Technical Data Sizes 2" thru 36"

Features and Benefits

- Minimizes piping support with the compact wafer style body. The Prince wafer check valves are two to three times lighter than traditional full-bodied check valves.
- Application specific problems are solved with the many Prince options. Options include silicone-free cleaning, oxygen-cleaning, vertical service valves, left hand valves, levers, weights and cushions.
- For media with fibrous matter in it, the external spring protects the fiber from wrapping around the spring and preventing valve closure.
- Maintenance is minimal with the field replaceable O-ring seat available in all styles and sizes.

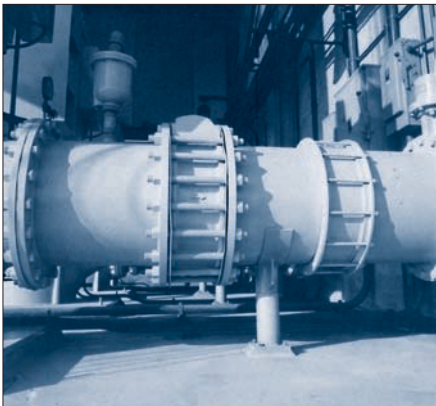

Applications

The Prince Wafer Check Valve is used to stop flow reversal in chemical refineries, ammonia compressors, waste water treatment plants, HVAC systems and most other industrial applications.

Technical Data

Size Range	: 2" thru 36"
Pressure Rating	: 150 - 740 psi
ANSI Flange Rating	: 125 - 300

Prince Wafer Check Valves

Sizes 2" thru 36"

Product Summary

Series	Rating	ANSI Flange (psi)	Pressure Rating (in.)	Size Material	Body Disc/Arm	Bushing/Bearing	Seat	Spring	Shaft Seal	Plug or Hardware	Outside Hardware
Figure 809	300	740	2"-12"	Carbon Steel	316 SS	N/A	TFE	316 SS (Std.) Inconel® 750	Carbon Steel	N/A	
Figure 810	125	150	2"-12"	Cast Iron	316 SS	N/A	BUNA-N (Std.) EPDM Fluoroelastomer TFE Metal-to-metal	316 SS (Std.) 2-5 inch 17-7 PH SS (Std.) 6-12 inch Inconel® 750	Carbon Steel	N/A	
	150	285	2"-12"	Carbon Steel 316 SS	316 SS	N/A	BUNA-N (Std.) EPDM Fluoroelastomer TFE Metal-to-metal	316 SS (Std.) 2-5 inch 17-7 PH SS (Std.) 6-12 inch Inconel® 750	Carbon Steel	N/A	
Figure 813	125	150	2"-12"	Cast Iron	316 SS	Bronze	BUNA-N (Std.) EPDM Fluoroelastomer TFE Metal-to-metal	316 SS (Std.) Inconel® 750	BUNA-N (Std.) EPDM Fluoroelastomer	• 2 Pos Adjustable Spring (Std.) • Lever • Adjustable Weight	
	150	285	2"-12"	Carbon Steel 316 SS	316 SS	Bronze 316 SS	BUNA-N (Std.) EPDM Fluoroelastomer TFE Metal-to-metal	316 SS (Std.) Inconel® 750	BUNA-N (Std.) EPDM Fluoroelastomer	• 2 Pos Adjustable Spring (Std.) • Lever • Adjustable Weight	
Figure 815	125	150	12"-36"	Cast Iron	316 SS	Bronze	BUNA-N (Std.) EPDM Fluoroelastomer Ni-AB 316 SS	Carbon St. (Std.) 316 SS	N/A	• Adjustable Spring • Lever • Adjustable Wt. (Std.) • Hydraulic Cushion • Limit Switch	
	150	230	12"-20"	Carbon Steel 316 SS	316 SS	Bronze	BUNA-N (Std.) EPDM Fluoroelastomer Ni-AB 316 SS	Carbon St. (Std.) 316 SS	N/A	• Adjustable Spring • Lever • Adjustable Wt. (Std.) • Hydraulic Cushion • Limit Switch	
	150	150	24"-36"	Carbon Steel 316 SS	316 SS	Bronze	BUNA-N (Std.) EPDM Fluoroelastomer Ni-AB	Carbon St. (Std.) 316 SS	N/A	• Adjustable Spring • Lever • Adjustable Wt. (Std.) • Hydraulic Cushion • Limit Switch	

Notes

1. Left hand versions available on all external spring models for horizontal service.
2. Not for use in pulsating or reciprocating services.

Check Valve Selection Diagram

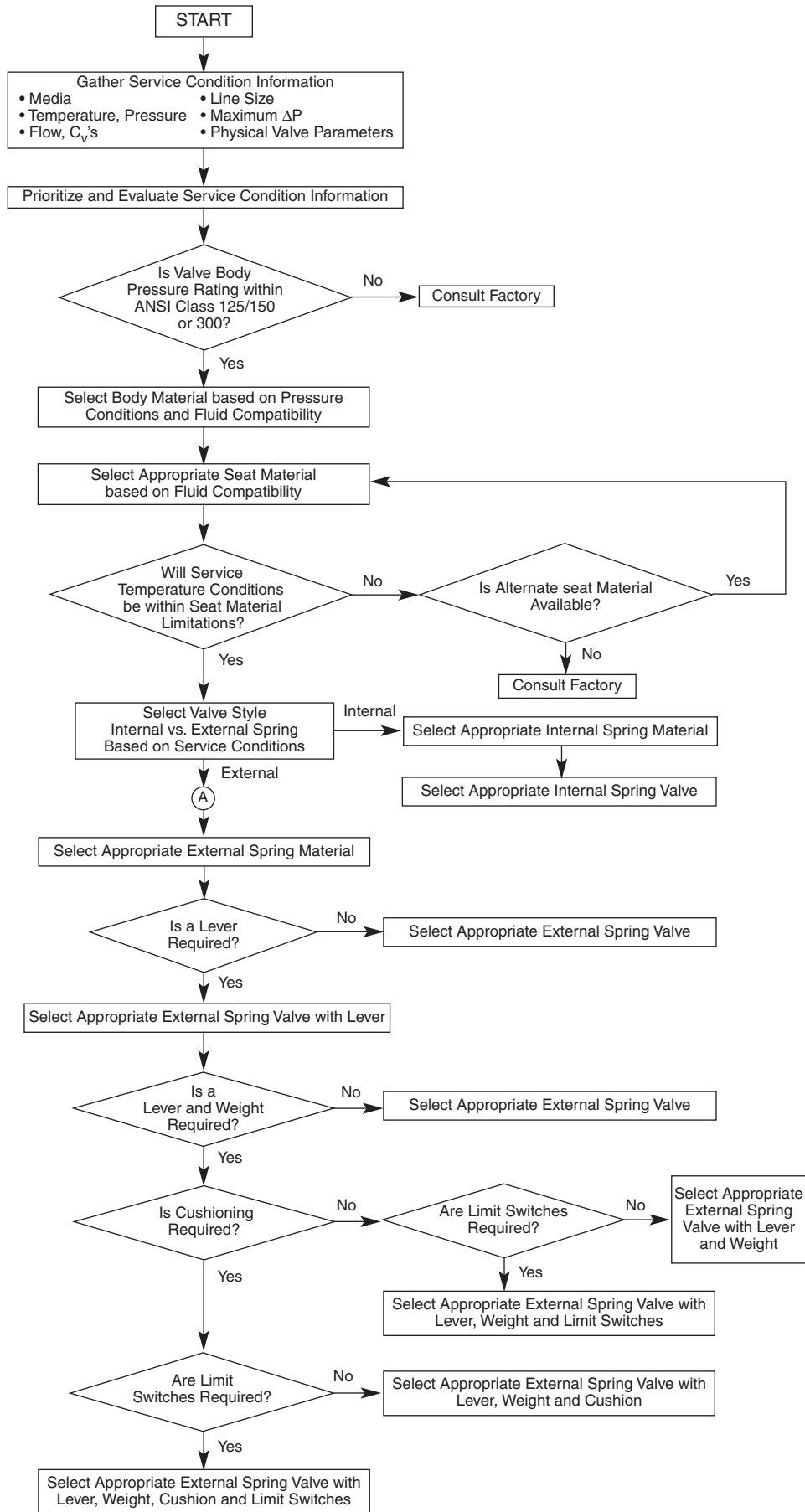

Prince Wafer Check Valves

Sizes 2" thru 36"

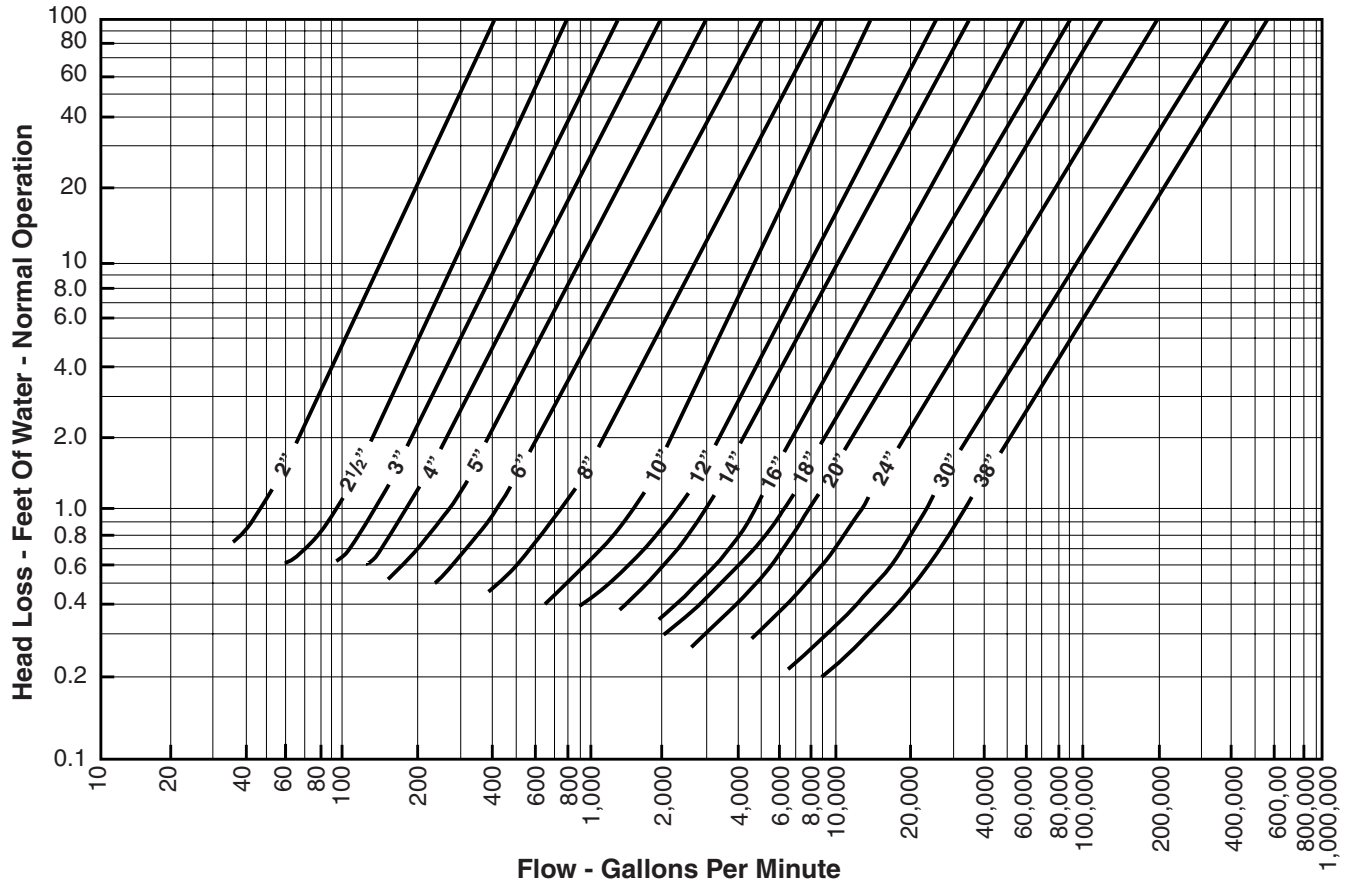

Notes

1. Curves are for water at 60°F.
2. Feet of water x 0.4335 = psi
3. Use curves for estimating purposes only. Performance is based upon ideal inlet and outlet conditions with no springs or weights.

Disc Cracking Pressure

All valves equal approximately 0.5 psi without lever/weight or cushion. For valves with lever/weight or cushion, contact factory.

Typical Data – Air Flow at 60° – S.C.F.M.

Pressure

Drop psi	2"	2½"	3"	4"	5"	6"	8"	10"	12"	14"	16"	18"	20"	24"	30"	36"
0.1	85	235	275	360	525	855	1,555	2,875	4,710	5,200	8,565	11,700	16,000	30,600	47,750	77,100
0.2	120	330	390	510	745	1,210	2,200	4,050	6,650	7,350	12,110	16,500	22,550	43,500	67,500	109,000

Flow Coefficient - C_v

Size	2"	2½"	3"	4"	5"	6"	8"	10"	12"	14"	16"	18"	20"	24"	30"	36"
C _v	70	190	225	295	430	700	1,270	2,350	3,850	4,250	7,000	9,550	13,000	25,000	39,000	63,000

For Liquids

$$\text{Pressure Drop} = \text{S.G.} \left(\frac{Q_L}{C_V} \right)^2$$

Where:

- Q_L = Flow in gallons per minute
- S.G. = Specific Gravity of Liquid
- C_V = Valve flow coefficient from table

Note: 30 fps is the nominal maximum allowable velocity for liquids.

For Gases

$$\text{Pressure Drop} = \text{S.G.} \frac{QV^2 GT}{512 P_1 C_V^2}$$

Where:

- QV = Flow in standard cubic feet per minute
- P₁ = Upstream pressure absolute (psi + 14.7)
- G = Specific Gravity of Gas
- T = Temperature (Rankine) (°F + 460°)
- C_V = Valve flow coefficient from table

Note: 120 fps is the nominal maximum velocity for gases.

Note

Where valve construction consists of more than one material, the effective service range of the valve is the same as that of the most restrictive material in the valve.

Size – Temperature – Pressure Ratings

Figure 809

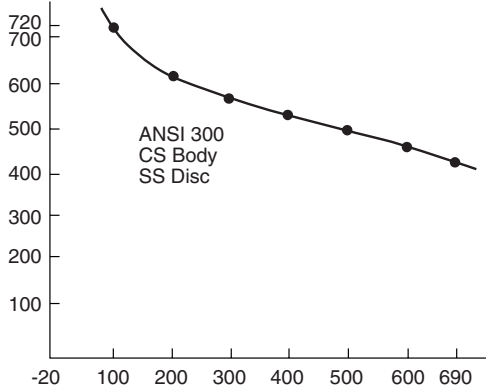

Figures 810 and 813

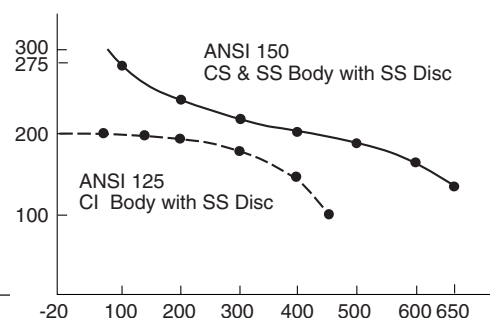
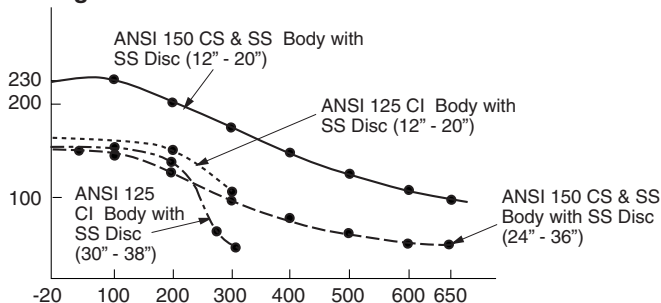

Figure 815



Seat Temperature Ratings

NBR	0 – 212°F
EPDM	-40 – 250°F
FKM	-40 – 400°F
TFE	-40 – 300°F
Metal	Refer to Temperature/Pressure Rating Charts

Prince Wafer Check Valves

Sizes 2" thru 36"

Materials of Construction – Metals

Part	Material Code	Common Designation	Specification
Body	102	Carbon Steel	ASTM A-216 WCB
	109-1	316 SS	ASTM A351 Grade CF8M
	134	Cast Iron	ASTM A-126 Class B
Disc	109-1	316 SS	ASTM A351 Grade CF8M
Arm	109-1	316 SS	ASTM A351 Grade CF8M
Disc Arm	109-1	316 SS	ASTM A351 Grade CF8M
Stem	109-2	316 SS	ASTM A-276 Gr. 316
	164	18-8 SS	ASTM A-276 Gr. 304
Spring	109-3	316 SS	ASTM A-313 Type 316
	120	Inconel® X750	AMS 5698/5699
	201	17-7 PH SS	AMS 5673 Cond. C (Age Hardened)
Bushing	109-2	316 SS	ASTM A-276 Gr. 316
	149	Sintered Bronze	SAE 841
	936	Bronze	ASTM B505 Alloy C93200
Seat Ring	109-2	316 SS	ASTM A-276 Gr. 316
	162	Nickel Aluminum Bronze	ASTM B148 Alloy C955

Materials of Construction – Seals

Type	Material Code	Common Designation	Temperature Rating
Elastomer	230	BUNA-N	0° to 212°F
	414	EPDM	-40° to 250°F
	440	Fluoroelastomer	-40° to 400°F
Polymer	500	TFE	-40° to 300°F
Metal	109	316 SS	Refer to the applicable disc temperature rating on Page 5.

Note

Specifications listed are not all-inclusive. Other specifications may apply. This listing is intended for use as a guideline only. User should determine those materials best suited for their particular application. Assistance is available from Tyco Valves and Controls.

Flange and Bolting Data – Figure 809

ANSI CLASS 300

Size (in.)	Diameter of Bolt Circle	No. of Bolts	Bolt Thread
2	5	8	5/8 - 11
3	6 ⁵ / ₈	8	3/4 - 10
4	7 ⁷ / ₈	8	3/4 - 10
5	9 ¹ / ₄	8	3/4 - 10
6	10 ⁵ / ₈	12	3/4 - 10
8	13	12	7/8 - 9
10	15	16	1 - 8
12	18	16	1 ¹ / ₈ - 7

Flange and Bolting Data –
 Figures 810, 813, and 815

ANSI CLASS 125/150

Size (in.)	Diameter of Bolt Circle	No. of Bolts	Bolt Thread
2	4 ³ / ₄	4	5/8 - 11
2 ¹ / ₂	5 ¹ / ₂	4	5/8 - 11
3	6	4	5/8 - 11
4	7 ¹ / ₂	8	5/8 - 11
5	8 ¹ / ₂	8	3/4 - 10
6	9 ¹ / ₂	8	3/4 - 10
8	11 ³ / ₄	8	3/4 - 10
10	14 ¹ / ₄	12	7/8 - 9
12	17	12	7/8 - 9
14	18 ³ / ₄	12	1 - 8
16	21 ¹ / ₄	16	1 - 8
18	22 ³ / ₄	16	1 ³ / ₄ - 7
20	25	20	1 ³ / ₄ - 7
24	29 ¹ / ₂	20	1 ¹ / ₄ - 7
30 ¹	36	28	1 ¹ / ₄ - 7
36 ¹	42 ³ / ₄	32	1 ¹ / ₂ - 6

Note

1. ANSI Class 125 Only

Correct Position

Incorrect Position

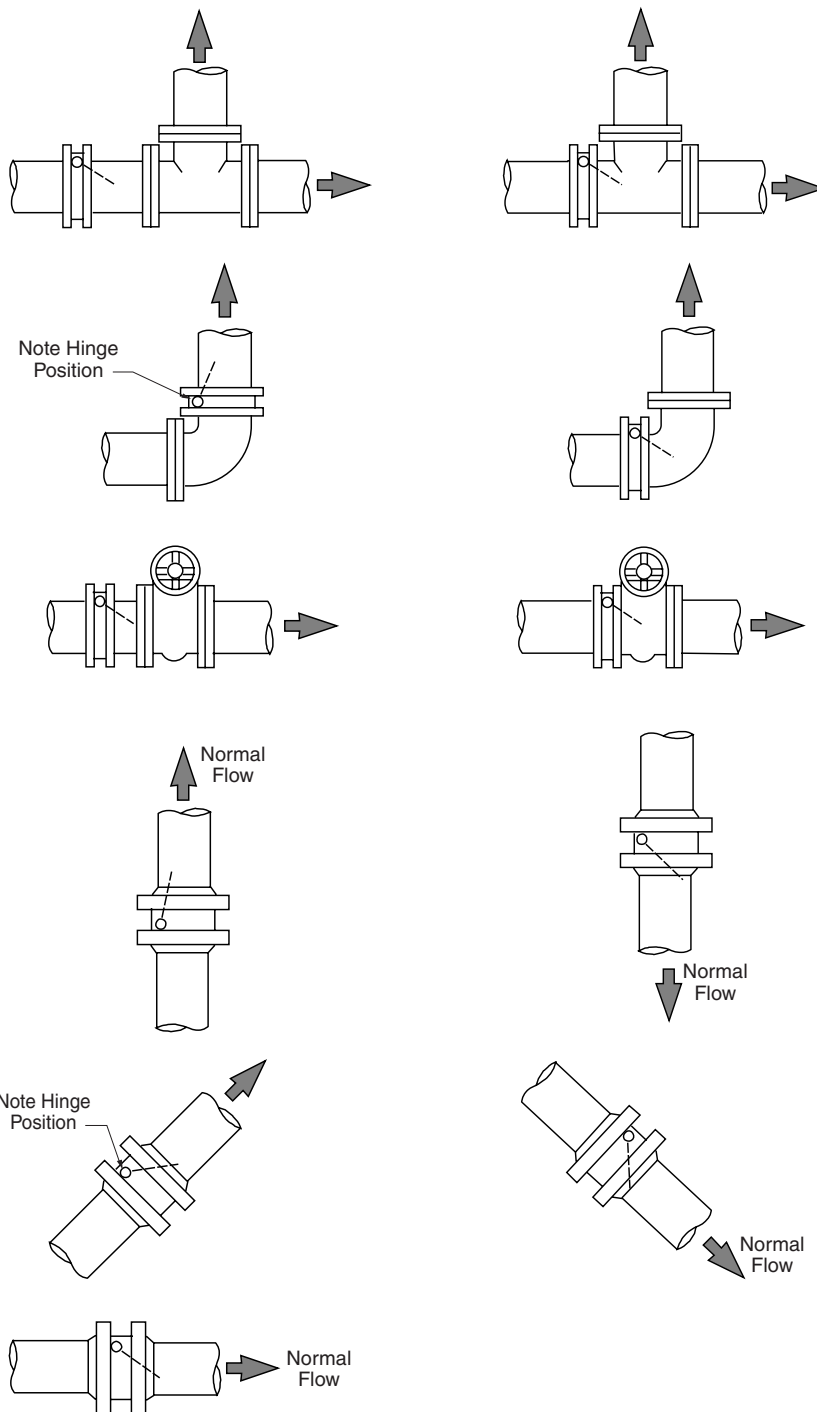

Recommendations for Installation Position

1. Position the check valve to promote smooth flow.
2. Allow clearance for disc movement.
3. Install the valve in horizontal or upward flow for proper valve closure.

Caution: Do not use with reciprocating compressors, or in other pulsating services.

Prince Wafer Check Valves

Sizes 2" thru 36"

Figure 809 – Sizes 3" thru 6"

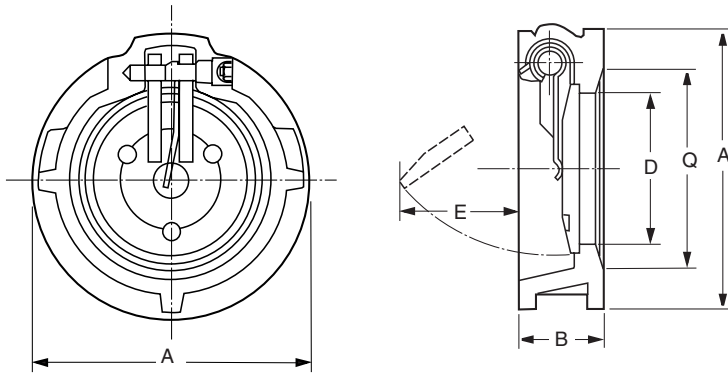

Figure 809 Valve Dimensions (Inches) Sizes 3" thru 6"

Size	A	B	Q ¹	D	E	Wt. (lbs.)
3	5 ⁷ / ₈	2	3 ¹ / ₈	2 ¹ / ₁₆	2	7
4	7 ¹ / ₈	2 ¹ / ₄	3 ¹⁵ / ₁₆	3 ¹ / ₃₂	2	11
5	8 ¹ / ₂	2 ¹ / ₂	5 ⁵ / ₃₂	3 ⁷ / ₈	3	15
6	9 ⁷ / ₈	2 ³ / ₄	6 ¹ / ₁₆	4 ³ / ₄	3 ¹³ / ₁₆	22

Note

1. The Q dimension is the minimum pipe or companion flange inside diameter for proper valve operation.

Figure 810 – Sizes 2" thru 12"

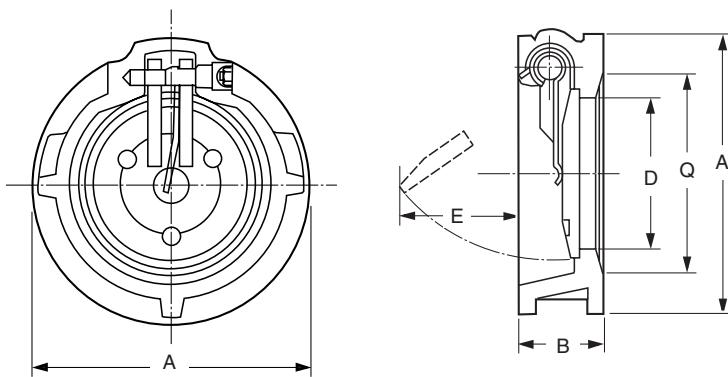

Figure 810 Valve Dimensions (Inches) Sizes 2" thru 12"

Size	A	B	Q ¹	D	E	Wt. (lbs.)
2	4 ¹ / ₈	1 ³ / ₄	2 ¹ / ₁₆	1 ¹⁷ / ₃₂	1 ³ / ₁₆	4
2 ¹ / ₂	4 ⁷ / ₈	1 ⁷ / ₈	2 ¹⁵ / ₃₂	1 ³ / ₄	1 ¹ / ₁₆	5
3	5 ³ / ₈	2	3 ¹ / ₁₆	2 ¹ / ₁₆	1 ⁵ / ₈	7
4	6 ⁷ / ₈	2 ¹ / ₄	4 ¹ / ₃₂	3 ¹ / ₃₂	2 ¹ / ₄	11
5	7 ³ / ₄	2 ¹ / ₂	5 ¹ / ₃₂	3 ⁷ / ₈	3	15
6	8 ³ / ₄	2 ³ / ₄	6 ¹ / ₁₆	4 ³ / ₄	3 ³ / ₄	22
8	11	2 ¹⁵ / ₁₆	7 ³ / ₃₂	6 ⁷ / ₁₆	4 ¹⁹ / ₃₂	30
10	13 ³ / ₈	3 ¹ / ₈	10	7 ⁵ / ₈	6 ⁷ / ₁₆	58
12	16 ¹ / ₈	3 ¹ / ₂	12	9 ¹ / ₂	8 ¹ / ₈	85

Note

1. The Q dimension is the minimum pipe or companion flange inside diameter for proper valve operation.

Figure 813 (with Optional Lever and Weight) Sizes 2" thru 12"

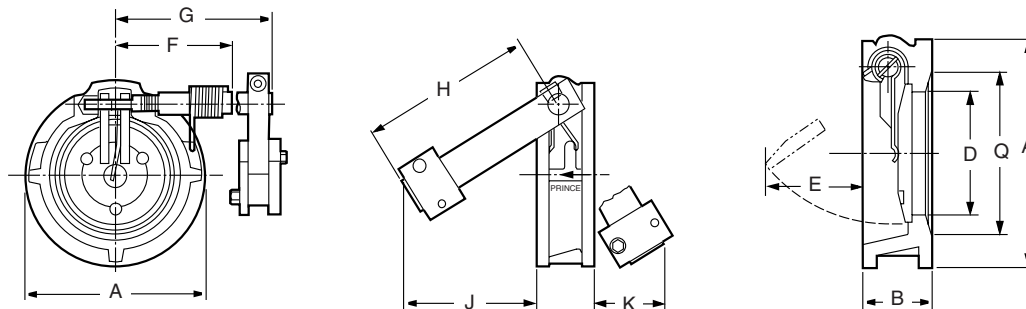

Figure 813 Valve Dimensions (Inches) Sizes 2" thru 12"

Size	A	B	Q ¹	D	E	F	G	H	J	K	Wt. (lbs.)
2	4 ¹ / ₈	1 ³ / ₄	2 ¹ / ₁₆	1 ¹⁷ / ₃₂	1 ³ / ₁₆	3 ¹ / ₁₆	4 ²³ / ₃₂	6 ¹ / ₂	5 ⁵ / ₃₂	2 ²¹ / ₃₂	5
2 ¹ / ₂	4 ⁷ / ₈	1 ⁷ / ₈	2 ¹⁵ / ₃₂	1 ¹⁷ / ₃₂	1 ¹ / ₁₆	3 ⁵ / ₁₆	5 ⁷ / ₃₂	7 ¹ / ₂	5 ⁷ / ₈	3 ³ / ₃₂	6
3	5 ³ / ₈	2	3 ¹ / ₁₆	2 ¹ / ₁₆	1 ⁵ / ₈	3 ¹ / ₂	5 ¹¹ / ₁₆	8 ¹ / ₂	6 ¹³ / ₁₆	3 ⁵ / ₈	9
4	6 ⁷ / ₈	2 ¹ / ₄	4 ¹ / ₃₂	3 ¹ / ₃₂	2 ¹ / ₄	3 ¹ / ₄	6 ¹³ / ₃₂	8 ¹ / ₂	6 ³ / ₄	3 ¹³ / ₃₂	13
5	7 ³ / ₄	2 ¹ / ₂	5 ¹ / ₃₂	3 ⁷ / ₈	3	5 ¹⁵ / ₃₂	7 ⁷ / ₃₂	8 ³ / ₈	6 ¹⁹ / ₃₂	3 ¹ / ₂	19
6	8 ³ / ₄	2 ³ / ₄	6 ¹ / ₁₆	4 ³ / ₄	3 ²⁵ / ₃₂	5 ²⁹ / ₃₂	7 ³ / ₄	8 ³ / ₈	6 ²¹ / ₃₂	3 ¹ / ₄	24
8	11	2 ¹⁵ / ₁₆	7 ³¹ / ₃₂	6 ⁷ / ₁₆	4 ⁵ / ₈	6 ³¹ / ₃₂	9 ⁵ / ₃₂	9 ³ / ₈	7 ⁷ / ₁₆	3 ⁵ / ₈	32
10	13 ³ / ₈	3 ¹ / ₈	10	7 ⁵ / ₈	6 ⁷ / ₁₆	5 ⁵ / ₁₆	10 ¹³ / ₃₂	13 ³ / ₈	8 ¹ / ₁₆	4 ³ / ₁₆	60
12	16 ¹ / ₈	3 ¹ / ₂	12	9 ¹ / ₂	8 ¹ / ₈	6 ¹ / ₄	12 ⁷ / ₃₂	12	9 ³ / ₈	4 ¹¹ / ₁₆	87

Note

1. The Q dimension is the minimum pipe or companion flange inside diameter for proper valve operation.

Figure 815 (with Optional Cushion) Sizes 12" thru 36"

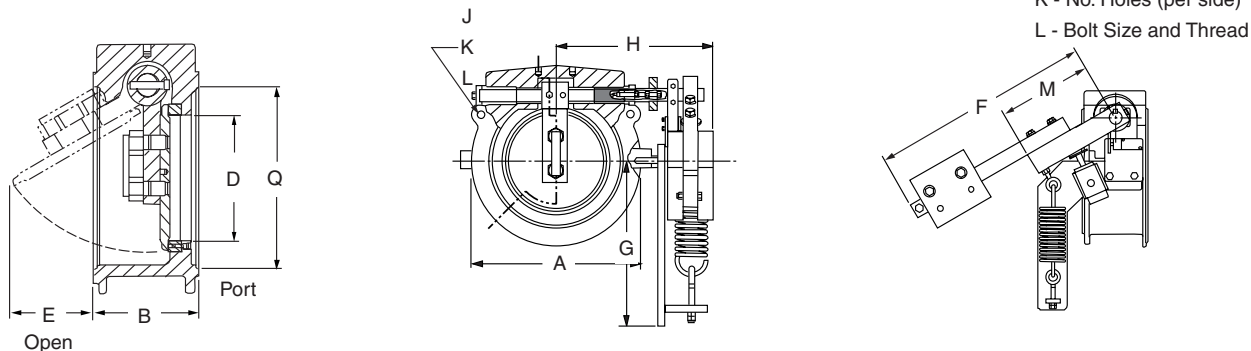

Figure 815 Valve Dimensions (Inches) Sizes 12" thru 36"

Size	A	B	Q ¹	D	E	F	G	H	J	K	L	M	Wt. (lbs.)
12	16	4 ³ / ₄	12	9 ¹ / ₂	7 ⁷ / ₃₂	18	7 ¹ / ₂	15 ³ / ₄	17	4	7/8 - 9	4 ⁵ / ₈	212
14	17 ⁵ / ₈	7 ³ / ₄	13 ¹ / ₄	10 ³ / ₁₆	6 ³ / ₄	30	20 ⁷ / ₃₂	17 ¹ / ₄	18 ³ / ₄	4	1 - 8	12 ³ / ₄	350
16	20 ¹ / ₈	8 ³ / ₄	15 ¹ / ₄	11 ³ / ₁₆	7 ³¹ / ₃₂	30	19 ⁵ / ₃₂	18 ⁵ / ₈	21 ¹ / ₄	6	1 - 8	12 ³ / ₄	410
18	21 ¹ / ₂	8 ³ / ₄	17 ¹ / ₄	12 ¹¹ / ₁₆	9 ³ / ₈	30	18 ³ / ₁₆	19 ³ / ₈	22 ³ / ₄	4	1 ¹ / ₈ - 7	12 ³ / ₄	450
20	23 ⁵ / ₈	9 ³ / ₄	19 ¹ / ₄	15	11 ⁷ / ₁₆	30	17 ¹ / ₄	20 ¹ / ₂	25	6	1 ¹ / ₈ - 7	14	775
24	28	9 ³ / ₄	23 ¹ / ₄	18 ¹ / ₂	15	30	16	22 ³ / ₄	29 ¹ / ₂	6	1 ¹ / ₄ - 7	14	925
30	34 ¹ / ₂	9 ³ / ₄	30	23 ¹ / ₂	19 ⁷ / ₃₂	30	26	26 ³ / ₄	36	8	1 ¹ / ₄ - 7	14	1225
36	41 ¹ / ₈	14 ¹ / ₂	35	28	19 ⁷ / ₁₆	40	23 ⁷ / ₁₆	38 ¹⁵ / ₁₆	42 ³ / ₄	8	1 ¹ / ₂ - 6	20 ¹ / ₈	2100

Note

1. The Q dimension is the minimum pipe or companion flange inside diameter for proper valve operation.

Chemical – Fractionating Column

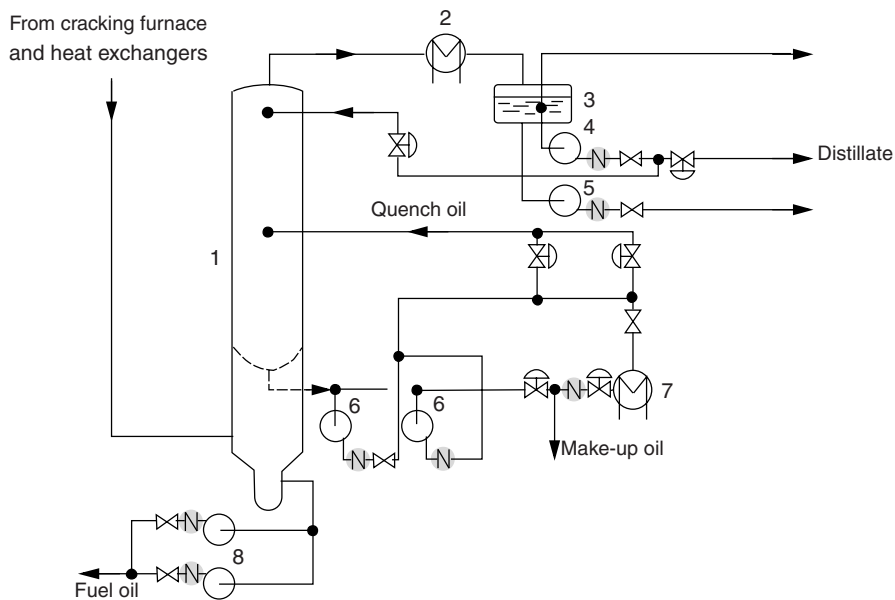

Diagram Key

1. Fractionating column
2. Coolers
3. Distillate drum
4. Distillate reflux and product pumps
5. Sour water pumps
6. Quench oil pumps
7. Quench oil rundown cooler
8. Fuel oil stripping pumps

Legend

- = Prince Check Valve
- = Block Valve
- = Control Valve

Petrochemical – Compressor and Light End Fractionating Section

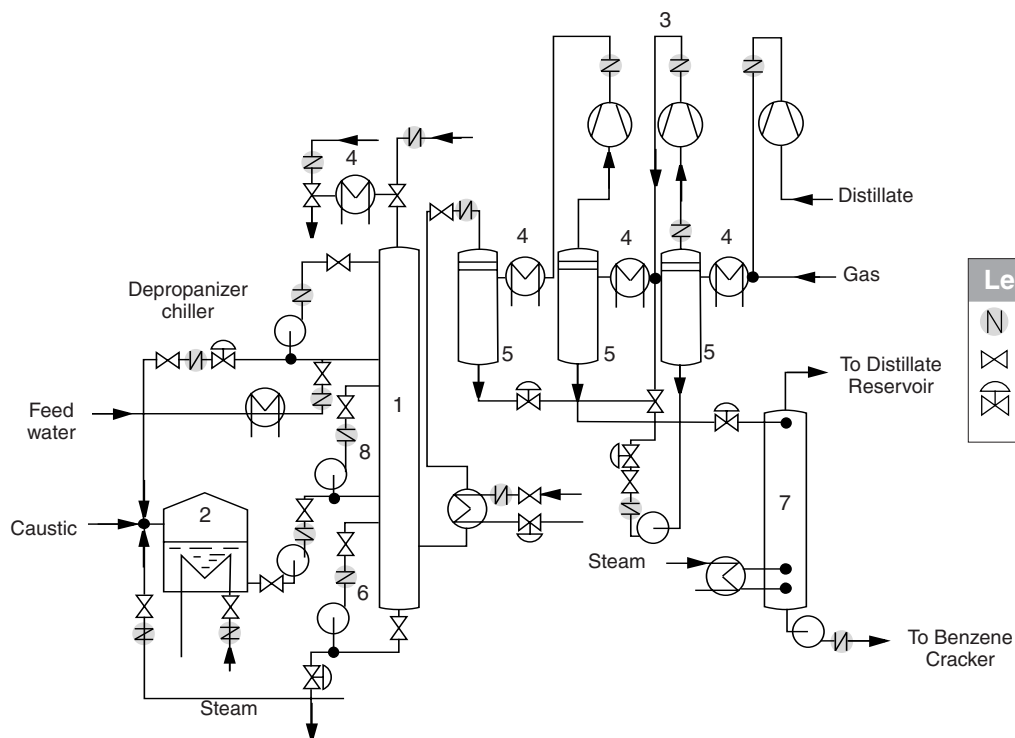

Diagram Key

1. Caustic scrubber
2. Caustic surge tank
3. Three-stage gas compressor
4. Aftercollers
5. Separators
6. Caustic pumps
7. Distillate stripper



Legend

- = Prince Check Valve
- = Block Valve
- = Control Valve

Diagram Key

1. Continuous digester
2. Heat exchanger - caloriser
3. Heat exchanger
4. Condensate vessel
5. Flash tanks

Legend

-  = Prince Check Valve
-  = Block Valve
-  = Control Valve

Pulp and Paper – Continuous Digester

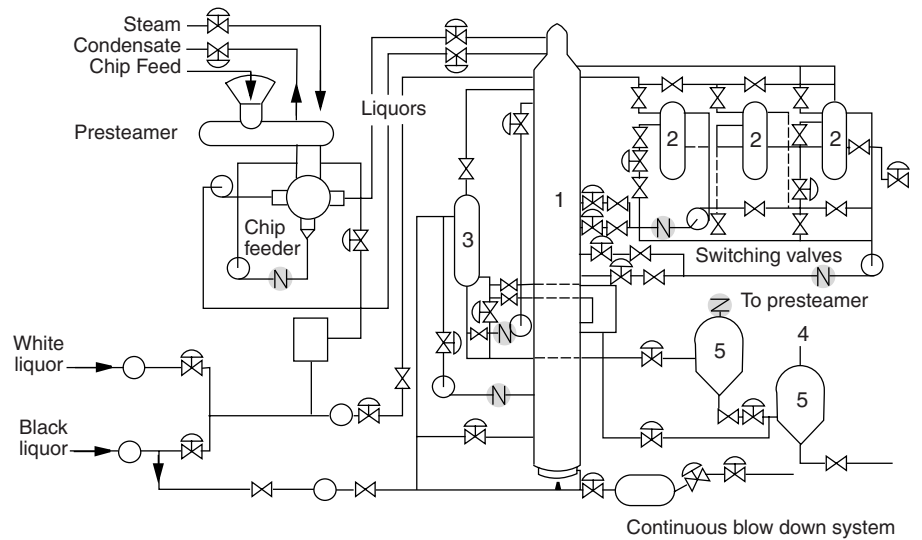

Diagram Key

1. Boilers
2. Pumps
3. Expansion tank
4. Fan coil units

Legend

-  = Prince Check Valve
-  = Block Valve
-  = Control Valve

HVAC – Three Boiler Water Heating System

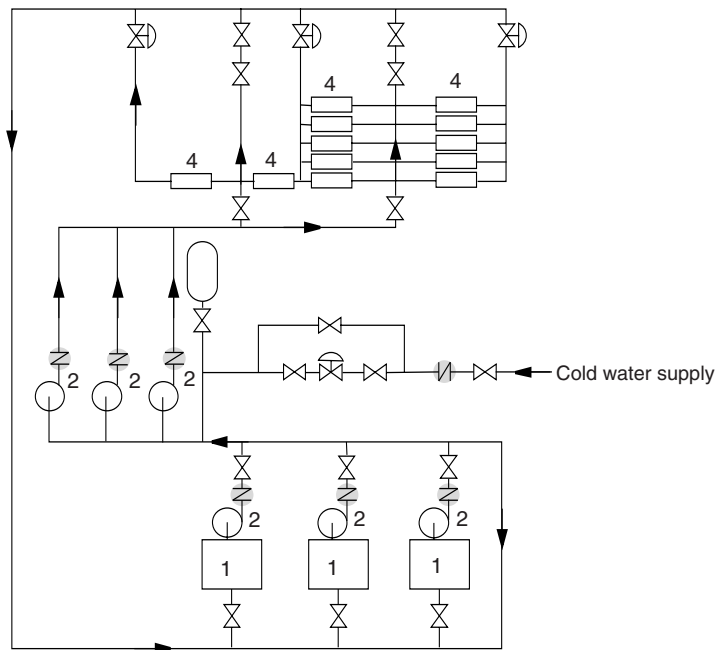

Prince Wafer Check Valves

Sizes 2" thru 36"

Materials Selection Guide

Material	Cast Iron	Carbon Steel	Stainless Steel	BUNA-N	EPDM	Fluoroelastomer	TFE
Acetaldehyde	A	A	A	C	C	B	A
Acetic Acid, Air Free	C	C	B	C	A	C	A
Acetone	A	A	A	C	C	C	A
Acetylene	A	A	A	B	A	A	A
Alcohols	A	A	A	A	A	B	A
Aluminum Sulfate	C	C	A	A	A	A	A
Ammonia	A	A	A	B	B	C	A
Ammonium Nitrate	C	A	A	B	A	A	A
Ammonium Sulfate	C	C	A	A	A	A	A
Asphalt	A	A	A	C	C	B	A
Beer	B	B	A	A	A	A	B
Benzene	A	A	A	C	C	A	A
Benzoic Acid	C	C	A	C	C	A	A
Boric Acid	C	C	A	A	A	A	A
Butane	A	A	A	B	C	B	A
Calcium Chloride	B	B	B	A	A	A	A
Carbolic Acid	B	B	A	C	B	A	A
Carbon Dioxide, Dry	A	A	A	B	A	A	A
Carbon Tetrachloride	B	B	B	C	C	A	A
Citric Acid	C	D	A	A	A	A	A
Coke Oven Gas	A	A	A	B	C	A	A
Copper Sulfate	C	C	B	A	A	A	A
Creosote	A	A	A	C	C	A	A
Ether	B	B	A	C	C	B	A
Ethyl Chloride	C	C	A	B	A	A	A
Ethylene	A	A	A	B	C	B	B
Ethylene Glycol	A	A	A	A	A	A	B
Fatty Acids	C	C	A	B	C	A	A
Ferric Chloride	C	C	C	C	B	A	A
Ferrous Chloride	C	C	C	C	B	D	A
Fluorocarbon Oil	C	C	A	D	C	C	A
Formic Acid	C	C	A	C	C	C	A
Freon 11	C	C	A	B	C	C	A
Freon 12	C	C	A	A	D	C	A
Freon 22	C	C	A	C	C	C	A
Fuel Oil	C	C	A	A	C	B	A
Fruit Juices	C	B	A	B	A	A	A
Gasoline	B	A	A	C	C	A	A
Glucose	D	D	A	A	A	A	A
Glycols	A	A	A	A	A	A	A
Green Liquor	C	C	A	B	B	B	A
Helium	C	B	A	A	A	B	A
Hexane	A	A	A	B	C	A	A
Hydrogen Gas	B	C	A	A	A	B	A
Ink	C	C	A	B	B	A	A
Isopropyl Alcohol	A	A	A	B	A	A	A
Kerosene	B	A	A	A	C	A	A
Ketones	A	A	A	C	C	C	A
Lead Acetate	C	C	B	A	A	A	A
Magnesium Hydroxide	C	A	A	A	A	A	A
Mash	C	C	A	B	A	A	A

Materials Selection Guide (cont.)

Material	Cast Iron	Carbon Steel	Stainless Steel	BUNA-N	EPDM	Fluoroelastomer	TFE
Mercury	C	A	A	A	C	D	A
Methane (Gas)	D	B	A	A	C	D	A
Mine Water (No Salts)	C	C	A	A	A	U	D
Naptha	B	A	A	C	C	A	A
Natural Gas (No H2S)	B	A	A	A	A	A	A
Nitrogen Gas	A	A	A	A	A	A	A
Oxygen Gas	A	A	A	B	A	A	A
Ozone	C	B	A	C	B	A	A
Paint Thinners	C	B	A	C	C	A	A
Pentane	A	A	A	A	C	B	A
Petrolatum	A	A	A	A	C	D	A
Phosphorous	C	C	A	B	C	A	A
Polystyrene Resins	C	C	A	C	C	D	B
Potash	C	C	A	B	A	A	A
Potassium Nitrate	C	A	A	A	A	A	A
Propane (LPG)	B	B	A	A	C	D	A
Pulp Stock	C	B	A	A	A	A	A
Sea Water	C	C	B	A	A	A	B
Sewage	B	B	A	A	A	B	A
Sodium Acetate	C	B	A	B	A	A	A
Sodium Chloride	C	C	B	A	A	A	A
Sour Gas	C	B	A	C	C	A	A
Steam	C	B	A	C	C	D	B
Toluene	A	A	A	C	C	A	A
Turpentine	C	B	A	C	C	A	A
Vinyl Acetate	C	A	A	C	D	C	B
Vinyl Chloride	C	C	A	C	D	D	B
Water	B	B	A	B	B	A	A
White Liquor	C	B	A	B	B	A	A
Xylene	C	C	A	C	C	A	A
Zinc Chloride	C	C	A	A	A	D	A

Notes

This information should be used as a general guide only.

Many variables other than the chemical resistance will influence the rate of corrosion and materials of construction.

Legend

- A = Can be or is successfully being used
- B = Proceed with caution
- C = Should not be used
- D = Information lacking

Figure 809 (Internal Spring) Specifications

General

The check valve shall be a wafer style (flangeless) swing check design utilizing a torsional spring to assist in faster closure. The valve must be capable of gravity closure should the loss of spring tension occur when system back pressure is present. Valves with discs hinged in a line crossing the valve diameter, or with center posts, are unacceptable.

Body/Seat

The body shall be of the one-piece construction and shall possess a machined dovetail groove for a polymer seal. The seal shall not be vulcanized to facilitate seat retention, and shall be field replaceable. The seal shall provide positive shut-off at both low and high pressure.

Disc

The valve shall utilize a one-piece disc/arm assembly. The disc shall completely cover the seal when in the closed position to provide positive seal regardless of disc orientation.

Disc/Stem Connection

The stem shall possess a double "D" design that when mated to the corresponding disc/arm assembly bore provides positive connection.

The valve shall be F809 as manufactured by Tyco Valves & Controls.

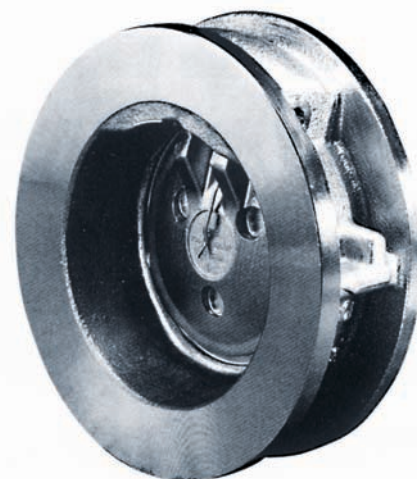

Figure 810 (Internal Spring) Specifications

General

The check valve shall be a wafer style (flangeless) swing check design utilizing a torsional spring to assist in faster closure. The valve must be capable of gravity closure should the loss of spring tension occur when system back pressure is present. Valves with discs hinged in a line crossing the valve diameter, or with center posts, are unacceptable.

Body/Seat

The body shall be of one-piece construction and shall (1) possess a machined dovetail groove for elastomer and polymer seals, or (2) possess an integral metal seat machined into the body when metal-to-metal seats are required. The resilient seals shall not be vulcanized to facilitate seat retention. The resilient seals shall be field replaceable. The resilient seals shall provide positive shut-off at both low and high pressure.

Disc

The valve shall utilize a one-piece disc/arm assembly. The disc shall completely cover the seal when in the closed position to provide positive seal regardless of disc orientation.

Disc/Stem Connection

The stem shall possess a double "D" design that when mated to the corresponding disc/arm assembly bore provides positive connection.

The valve shall be F810 as manufactured by Tyco Valves & Controls.

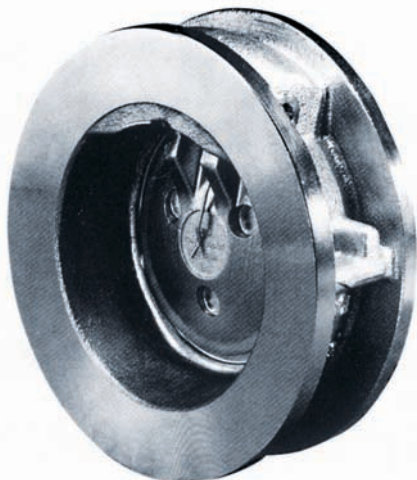
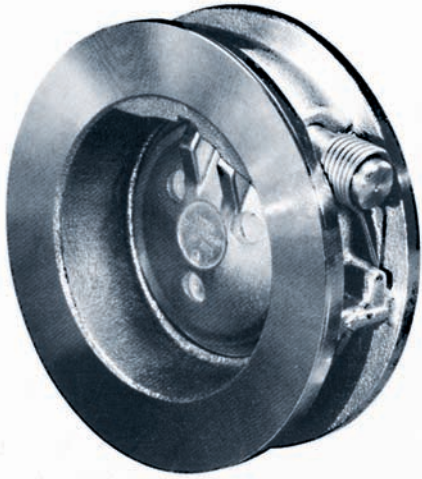

Figure 813 (External Spring) Specifications



General

The check valve shall be a wafer style (flangeless) swing check design utilizing a torsional spring to assist in faster closure. The valve must be capable of gravity closure should the loss of spring tension occur when system back pressure is present. Valves with discs hinged in a line crossing the valve diameter, or with center posts, are unacceptable. The valve shall have capability to add lever and/or weight for back-flush capabilities. The lever and/or weight assembly to be field installable. The external spring, lever and weight must be field adjustable.

Body/Seat

The body shall be of one-piece construction and shall (1) possess a machined dovetail groove for elastomer and polymer seals, or (2) possess an integral metal seat machined into the body when metal-to-metal seats are required. The resilient seals shall not be

vulcanized to facilitate seal retention. The resilient seals shall be field replaceable. The resilient seals shall provide positive shut-off at both low and high pressure.

Disc

The valve shall utilize a one-piece disc/arm assembly. The disc shall completely cover the seal when in the closed position to provide positive seal regardless of disc orientation.

Bushing and Disc/Stem Connection

The valve shall possess (2) stainless steel or bronze bushings to provide support and alignment to the disc/arm and stem. The stem shall possess a double "D" design that when mated to the corresponding disc/arm assembly bore provides positive connection.

The valve shall be F813 as manufactured by Tyco Valves & Controls.

Figure 815 (External Spring) Specifications

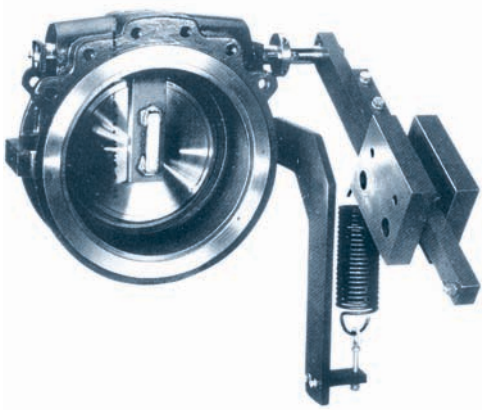

General

The check valve shall be a semi-lug, swing check design utilizing a tension spring to assist in faster closure. The valve must be capable of gravity closure should the loss of spring tension occur when system back pressure is present. The valve shall have the capability of adding an adjustable hydraulic cushion for those applications that require damping systems. The external spring (and the damping cushion) must be field adjustable.

Body/Seat

The body shall be of one-piece construction and shall (1) possess a machined dovetail groove for elastomer and polymer seals, or (2) possess a stainless steel or nickel aluminum bronze

seat ring. The metal seat ring shall have a machined dovetail groove to mechanically retain the elastomer seal. No vulcanized bonding or chemical bonding is permitted to facilitate seal retention. The seals shall be field replaceable. The elastomer seals to provide positive shut-off at both low and high pressure.

Disc

The disc shall completely cover the seat ring/seal when in the closed position to provide positive seal regardless of disc orientation.

The valve shall be F815 as manufactured by Tyco Valves & Controls.

Prince Wafer Check Valves

Sizes 2" thru 36"

Tyco Valves & Controls

www.tycovalves.com

The data presented in this bulletin is for general information only. Manufacturer is not responsible for acceptability of these products in relation to system requirements. Patents and Patents Pending in U.S. and foreign countries. All rights reserved. Printed in U.S.A. Tyco reserves the right to change product design and specifications without notice. © Copyright 2002.